



## **RESIDENTIAL DECK CHECKLIST**

### **PERMIT APPLICATION & SUBMITTAL REQUIREMENTS:**

- Complete and sign general permit application with all pertinent contractor information.
- Complete the electrical application, signed by the supervising electrician, and provide a copy of their electrical license.
- Contractors must obtain a Village Contractors license prior to issuance of permits (No bonds or insurance required.)
- Submit THREE (3) copies of a Plat of Survey for the property indicating:**
  - o Proposed deck location with dimensions and distance from the property lines drawn to scale.
  - o No portion of deck shall be located closer than six feet (6') from side and rear property line nor located in any utility or drainage easement.
  - o No portion of a pool deck shall be located closer than eight feet (8') from side and rear property line nor located in any utility or drainage easement.
- Submit THREE (3) copies of deck framing plan:**
  - o All plans must be drawn to scale.
  - o Specify the overall dimensions of the deck.
  - o Specify height above grade.
  - o Specify post and beam locations with dimensions indicating beam spans between posts.
  - o Specify nominal lumber sizes of all joists, beams, and posts.
  - o Specify pier diameter and depth.
  - o Specify pier to post and post to beam connection.
  - o Specify ledger board connection detail. Please note that attachments to exterior veneers (brick, masonry, stone) and to cantilevered floor overhangs or bay windows are prohibited.
  - o Specify stair location and dimensions including riser height and tread depth.
  - o Specify guard railing dimensions, including post spacing, height and baluster spacing.
  - o A GFCI tamper resistant receptacle is required within the perimeter of the deck not more than six feet six inches (6'-6") above deck surface.

### **Must comply with the following Codes:**

- o 2018 International Residential Code
- o 2017 National Electrical Code

**INSPECTIONS: Contractors must call 847-357-4220 for all inspections 24 hours in advance. Please have your permit number and job address available to schedule an inspection.**

- POST HOLE**
- FRAMING**
- ELECTRICAL (IF REQUIRED)**
- FINAL**

## DECK BUILDING REQUIREMENTS

### General:

- A deck must be designed to support a 40 lb. per square foot live load.
- Deck cannot be located closer than six feet (6') from any property line.
- No portion of deck is permitted to be located within any utility easement.
- A switch-controlled exterior light fixture is required at each exterior door from the house to the deck.
- Vegetation, top soil and construction debris shall be removed from the property and disposed of properly prior to the final inspection.

### Piers:

- Deck piers shall be a minimum of twelve (12") inches in diameter, extending a minimum of forty-two (42") inches below grade.
- The posts shall be attached to the piers with a galvanized post anchor with half inch (1/2") anchor bolt.

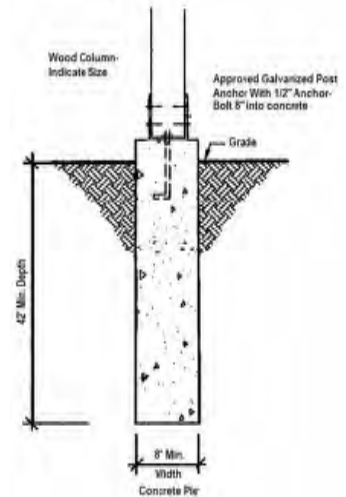

### Post:

- 4x4 post shall not exceed 6'-9"
- 4x6 post shall not exceed 8'-0"
- 6x6 post shall not exceed 14'-0"
- 8x8 post shall not exceed 14'-0"

### Ledger Board:

- Ledger board shall be a minimum two inch by eight inch.(2"x8")
- The deck ledger shall not be attached to exterior veneers (brick, masonry, stone), cantilevered floor overhangs or bay windows.
- The ledger board at the house shall not be attached directly over any type of siding.

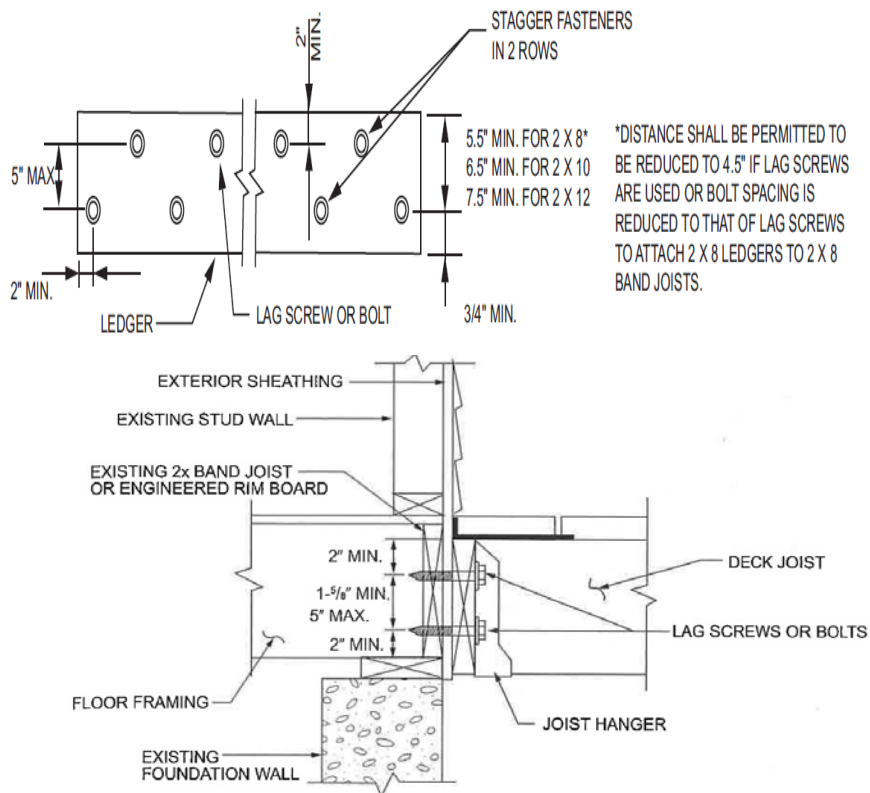

**Beams:**

- Beams shall be secured to supports by a minimum of two (2) half inch (1/2") diameter through bolts.
- Manufactured post-to-beam connectors shall be sized for the post and beam sizes. Bolts shall have washers under the head and nut.

**TYPICAL DECK JOIST SPANS**

**TABLE R507.5**  
**DECK BEAM SPAN LENGTHS<sup>a, b, c</sup> (feet - inches)**

SPECIES <sup>a</sup>	SIZE <sup>d</sup>	DECK JOIST SPAN LESS THAN OR EQUAL TO: (feet)						
		6	8	10	12	14	16	18
Southern pine	1 - 2 x 6	4-11	4-0	3-7	3-3	3-0	2-10	2-8
	1 - 2 x 8	5-11	5-1	4-7	4-2	2-10	3-7	3-5
	1 - 2 x 10	7-0	6-0	5-5	4-11	4-7	4-3	4-0
	1 - 2 x 12	8-3	7-1	6-4	5-10	5-5	5-0	4-9
	2 - 2 x 6	6-11	5-11	5-4	4-10	4-6	4-3	4-0
	2 - 2 x 8	8-9	7-7	6-9	6-2	5-9	5-4	5-0
	2 - 2 x 10	10-4	9-0	8-0	7-4	6-9	6-4	6-0
	2 - 2 x 12	12-2	10-7	9-5	8-7	8-0	7-6	7-0
	3 - 2 x 6	8-2	7-5	6-8	6-1	5-8	5-3	5-0
	3 - 2 x 8	10-10	9-6	8-6	7-9	7-2	6-8	6-4
	3 - 2 x 10	13-0	11-3	10-0	9-2	8-6	7-11	7-6
3 - 2 x 12	15-3	13-3	11-10	10-9	10-0	9-4	8-10	
Douglas fir-larch <sup>e</sup> , hem-fir <sup>e</sup> , spruce-pine-fir <sup>e</sup> , redwood, western cedars, ponderosa pine <sup>f</sup> , red pine <sup>e</sup>	3 x 6 or 2 - 2 x 6	5-5	4-8	4-2	3-10	3-6	3-1	2-9
	3 x 8 or 2 - 2 x 8	6-10	5-11	5-4	4-10	4-6	4-1	3-8
	3 x 10 or 2 - 2 x 10	8-4	7-3	6-6	5-11	5-6	5-1	4-8
	3 x 12 or 2 - 2 x 12	9-8	8-5	7-6	6-10	6-4	5-11	5-7
	4 x 6	6-5	5-6	4-11	4-6	4-2	3-11	3-8
	4 x 8	8-5	7-3	6-6	5-11	5-6	5-2	4-10
	4 x 10	9-11	8-7	7-8	7-0	6-6	6-1	5-8
	4 x 12	11-5	9-11	8-10	8-1	7-6	7-0	6-7
	3 - 2 x 6	7-4	6-8	6-0	5-6	5-1	4-9	4-6
	3 - 2 x 8	9-8	8-6	7-7	6-11	6-5	6-0	5-8
	3 - 2 x 10	12-0	10-5	9-4	8-6	7-10	7-4	6-11
	3 - 2 x 12	13-11	12-1	10-9	9-10	9-1	8-6	8-1

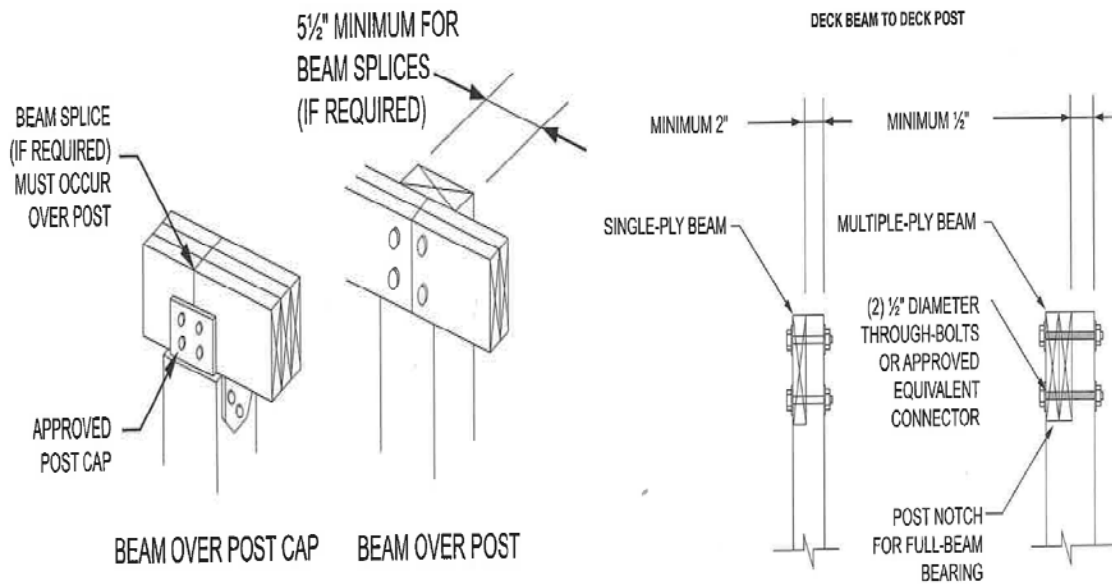

**Joist:**

- Maximum sixteen inches (16”) on center when using five-quarter (5/4”) inch nominal decking.
- Maximum twenty-four inches (24”) on center when using two (2”) inch nominal decking.

**DECK JOIST SPANS FOR COMMON LUMBER SPECIES (ft. - in.)**

SPECIES <sup>a</sup>	SIZE	ALLOWABLE JOIST SPAN <sup>b</sup>			MAXIMUM CANTILEVER <sup>c, f</sup>		
		SPACING OF DECK JOISTS (inches)			SPACING OF DECK JOISTS WITH CANTILEVERS <sup>e</sup> (inches)		
		12	16	24	12	16	24
Southern pine	2 x 6	9-11	9-0	7-7	1-3	1-4	1-6
	2 x 8	13-1	11-10	9-8	2-1	2-3	2-5
	2 x 10	16-2	14-0	11-5	3-4	3-6	2-10
	2 x 12	18-0	16-6	13-6	4-6	4-2	3-4
Douglas fir-larch <sup>d</sup> , hem-fir <sup>d</sup> spruce-pine-fir <sup>d</sup> ,	2 x 6	9-6	8-8	7-2	1-2	1-3	1-5
	2 x 8	12-6	11-1	9-1	1-11	2-1	2-3
	2 x 10	15-8	13-7	11-1	3-1	3-5	2-9
	2 x 12	18-0	15-9	12-10	4-6	3-11	3-3
Redwood, western cedars, ponderosa pine <sup>e</sup> , red pine <sup>e</sup>	2 x 6	8-10	8-0	7-0	1-0	1-1	1-2
	2 x 8	11-8	10-7	8-8	1-8	1-10	2-0
	2 x 10	14-11	13-0	10-7	2-8	2-10	2-8
	2 x 12	17-5	15-1	12-4	3-10	3-9	3-1

**Stairs:**

- Stairs shall have a minimum width of thirty-six inches (36”).
- Maximum riser height shall not exceed seven and three quarter inch (7-3/4”). The riser height shall be measured vertically between leading edges of the adjacent treads.
- Minimum tread depth is ten inches (10”). The tread depth shall be measured horizontally between the leading edge of nosing.
- Riser heights and tread depths shall not vary by more than three eights of an inch (3/8”).
- If the stair stringers land on an existing concrete pad or patio, field inspector shall verify whether the concrete pad is in good condition to support the stairs. If the existing slab is not deteriorated or visibly sinking into ground, the stair is permitted to land on the existing slab with no additional provisions for piers regardless of deck height.
- Decks which do not exceed a height of five feet (5') above grade, will be allowed to have their stair stringers land on a four inch (4”) thick concrete pad and/or concrete piers which extend forty-two inches (42”) below grade. The minimum pad size shall be twenty-four inches (24”) by the width of the stair. Be advised that if only piers are used, the riser height at the bottom of the stair to grade shall not exceed more than three eights of an inch (3/8”) difference between the remaining risers on the stair.
- Decks which exceed five feet (5') in height above grade must have their stair stringers bear on a minimum four (4”) inch thick concrete pad with piers which extend to a depth of forty-two inches (42”) below grade. Be advised that if piers and pad are used, the riser height at the bottom of the stair to grade shall not exceed more than three eights of an inch (3/8”) difference between the remaining risers on the stair.

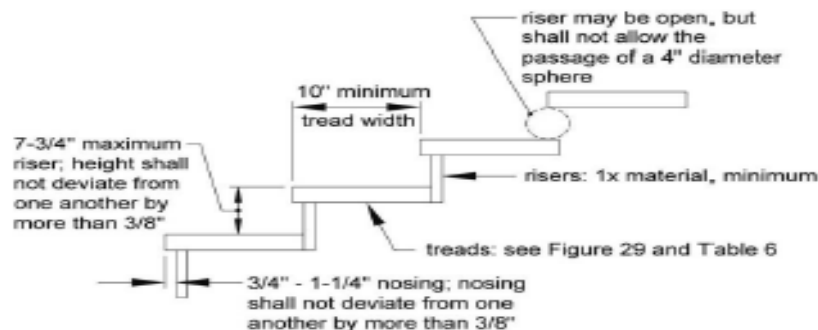

## Guards and handrails:

- All stairs with four (4) or more risers shall have a handrail on at least one side. The handrail height measured vertically for the sloped plane adjoining the tread nosing shall not be less than thirty-four (34") inches and not more than thirty-eight (38") inches from the top of stair to bottom.
- Handrails shall be graspable and shall be composed of decay-resistant and/or corrosion resistant material.
- Triangular opening on stair guard shall not permit the passage of a six inch (6") diameter sphere.
- Spacing between the four by four (4"x4") railing post shall not exceed thirty-six inches (36").
- Spacing between balusters and bottom of the deck rail shall not allow the passage of a four inch (4") diameter sphere.

